

Innovative Engineered Solutions

EMVO ROTARY VANE VACUUM PUMPS AND SUPERVANE VACUUM PACKAGE

EverestVacuum a brand of Everest Blower Systems Private Limited brings to its customers, **EMVO** Single Stage Oil Sealed Rotary Vane Vacuum Pumps and **SuperVane** (EMVO + MVB).



EMVO and **SuperVane** are used in a growing number of applications where a low-cost vacuum is required for the process industry. These pumps offer a compact plug and play vacuum. These pumps are amongst the most rugged in terms of operation and offer good reliability and ease of service which makes them a preferred choice of pump.

Rotary vane technology has been continuously developed and optimized over the decades, with an emphasis on operational reliability and efficiency. Rotary vane vacuum pumps are known throughout the industry for their modern and energy-efficient vacuum generation, in a wide range of applications. Whether for intermittent or continuous use, you can rely on the pumps for long term consistent use.

ENGINEERING | EVALUATION | DESIGNING **EverestVacuum**
MANUFACTURING | TESTING | EXECUTION | POST SALES AND SERVICE

Robust Pump for Indian Environment

EverestVacuum

EMVO Rotary Vane Vacuum Pumps

SALIENT FEATURES

- Robustness and reliability of operation
- Cost-Effective.
- Easy to service.

SECTORS SERVED

- Food Packaging and Processing
- Meat Packing
- Wood Working
- Rubber and Plastics
- Central Vacuum system for R&D Control
- Material Handling
- Medical Vacuum
- Chemical and Pharma: Drying and Conveying

OPERATING PRINCIPLE

EMVO Rotary Vane Vacuum Pump is an oil-sealed rotary displacement pump. The pumping mechanism consists of a housing, an eccentrically installed rotor, vanes that move radially under centrifugal and resilient forces and the inlet and outlet. The inlet valve is designed as a vacuum safety valve that is always open during operation. The working chamber is located inside the housing and is restricted by the stator, rotor and the vanes. The eccentrically installed rotor and vanes divide the working chamber into two separate compartments with variable volumes. As the rotor turns, gas flows into the enlarging suction chamber until it is sealed off by the second vane. The enclosed gas is then compressed until the outlet valve opens against atmospheric pressure. The outlet valve is oil-sealed. When the valve is open, a small amount of oil enters the suction chamber and not only lubricates it but also seals the vanes against the housing (stator).

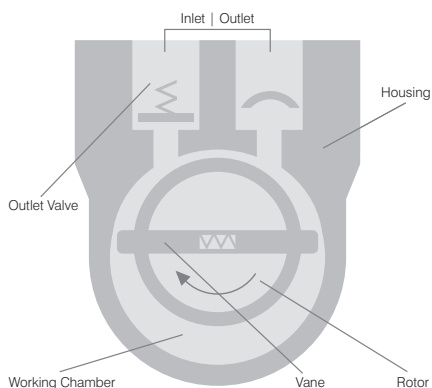

In the case of gas ballast operation, a hole to the outside is opened, which empties into the sealed suction chamber on the front side. As a result, the pressure needed to open the outlet valve is attained at relatively low compression during the compression pumping phase. This allows a displaced gas/vapor mixture to be expelled before the vapor starts to condense. The final pressure reached during operation with gas ballast is higher than in operation without gas ballast.

PLUG & PLAY
EMVO pumps are used where a low-cost vacuum is required
CONCEPT



PERFORMANCE CURVES | 50 HZ

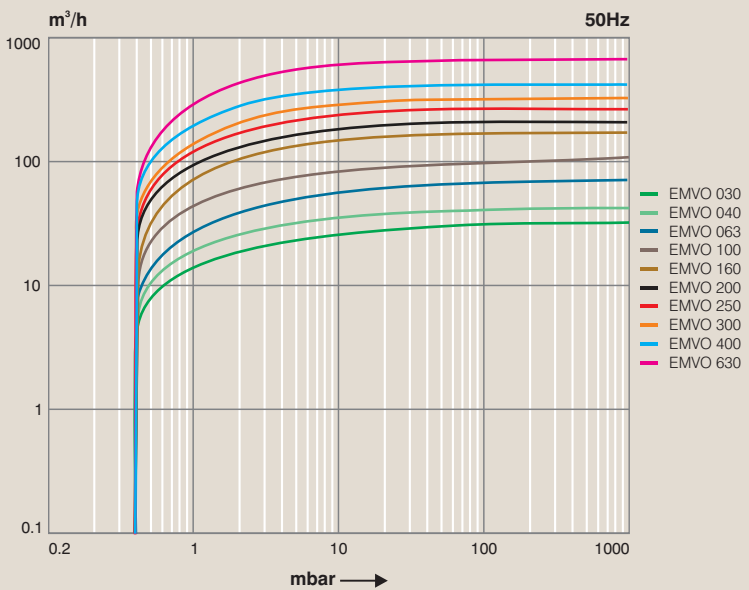

EVEREST SUPERVANE ROTARY PUMPS | EMVO SERIES

SPECIFICATIONS

Model	Nominal Displacement (m ³ /hr)		Ultimate Pressure		Motor Rating		Operating Speed		Sound Level	Operating Temp	Water Vapour Tolerance (max)	Water Vapour Capacity	Oil Filling	Approx Weight
	50 Hz	60 Hz	mBar	Torr	KW	RPM	dB(A)	°C	mBar	L/h	Ltr.	Kgs.		
	EMVO-6	6	7.2	2	1.5	0.35	-	50	40	-	-	0.3	12	
EMVO-8	8	9.6	0.5	0.37	0.37	1430	59	40	-	-	0.3	18		
EMVO-10	10	12	0.5	0.37	0.55	1420	58	40	-	-	0.4	20		
EMVO-16	16	19	2	1.5	0.55	3000	60	40	-	-	0.3	18		
EMVO-20	20	24	2	1.5	0.95	2850	61	40	-	-	0.4	20		
EMVO-30	30	36	0.5	0.37	2	1420	64	40	40	0.9	1	34		
EMVO-40	40	48	0.5	0.37	2	1420	67	40	40	0.9	1	38		
EMVO-63	63	76	0.5	0.37	2.55	1420	68	40	40	1.8	2	64		
EMVO-100	100	120	0.5	0.37	3.45	1420	70	40	40	2.8	2	75		

- Double Gas Ballast optional (OPT).
- Pumps can be supplied with FLP motors EMVO63 onwards.

EVEREST SUPERVANE ROTARY PUMPS | EMVO SERIES

SPECIFICATIONS

Model	Nominal Displacement (m ³ /hr)		Ultimate Pressure		Motor Rating (KW)		Operating Speed		Sound Level	Operating Temp	Water Vapour Tolerance (max)	Water Vapour Capacity	Oil Filling	Approx Weight
	50 Hz	60 Hz	mBar	Torr	50 Hz	60 Hz	RPM	dB(A)	°C	mBar	L/h	Ltr.	Kgs.	
	EMVO-160	160	190	0.5	0.37	5.5	-	1455	70	80	40	7.6	7	174
EMVO-200	200	240	0.5	0.37	5.5	-	1455	72	80	40	9.6	7	185	
EMVO-250	250	300	0.5	0.37	7.5	-	1455	72	85	40	12	7	202	
EMVO-300	300	360	0.5	0.37	7.5	-	1455	74	85	40	14	7	218	
EMVO-400	400	480	0.5	0.37	11	15	1000	70	40	40	19	13	550	
EMVO-630	630	760	0.5	0.37	15	18.5	1000	72	40	40	30	15	670	

Standard scope of supply

Oil separator filter | NRV at Suction | Gas Ballast | First Oil Fill | Electric Motor (Std.)

PERFORMANCE CURVES | 60 HZ

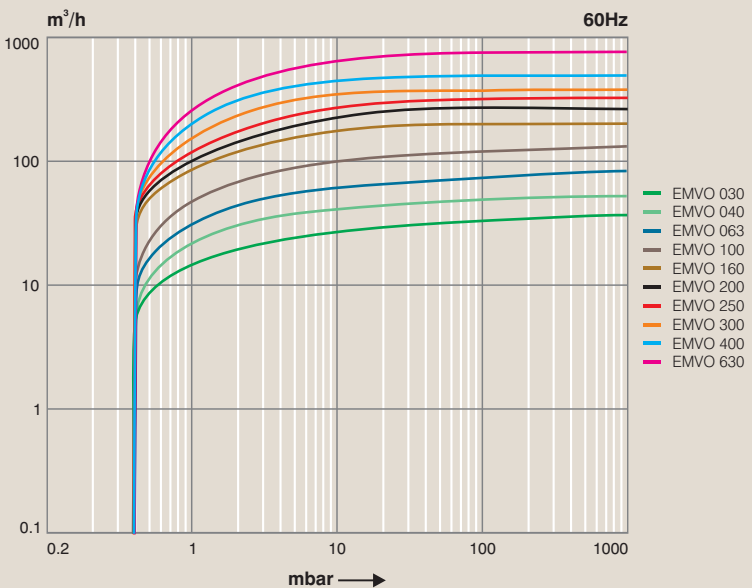

EVEREST ADVANTAGE HIGH VOLUMETRIC EFFICIENCY
LOW ENERGY CONSUMPTION | PACKAGE SUPPLY | PLUG AND PLAY CONCEPT

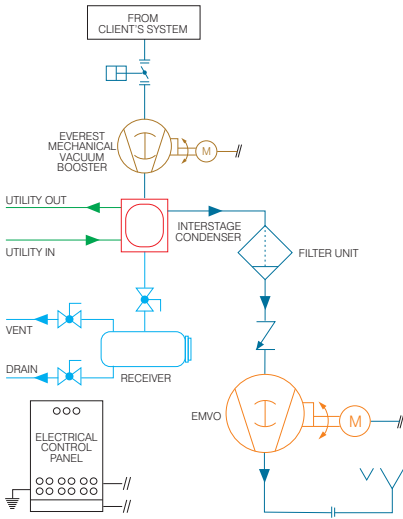

EVEREST SUPERVANE VACUUM PACKAGE

SPECIFICATIONS

Model	Supervane							
	400	800	1600	2000	3000	4000	5000	
NOMINAL	m3/hr	400	800	1600	2000	3000	4000	5000
DISPLACEMENT	CFM	235	470	950	1175	1770	2350	2950
ULTIMATE VACUUM	Torr	0.05	0.05	0.05	0.05	0.010	0.010	0.010
POWER CONNECTED	KW	5.70	11.00	13.00	16.50	18.50	22.00	27.50
ISOLATION VALVE	L/Min.	Electronic Solenoid+NRV (SS+PT FE)						
SKID STRUCTURE	MS	ISMC, IS:809 1989						
STANDARD ACC	Std	Inlet Filter; NRV; Interconnecting Piping; BVG with Siphon						

- Custom built systems can be designed to match customer requirements.
- Complete Vacuum Systems can be supplied with Filters, Condensers, Receivers and Automation.
- Complete system can be supplied in FLP configuration.

SUPERVANE 5000
SUPERVANE 4000
SUPERVANE 3000
SUPERVANE 2000

SUPERVANE 1600
SUPERVANE 800
SUPERVANE 400

EMVO 400
EMVO 300
EMVO 250
EMVO 100

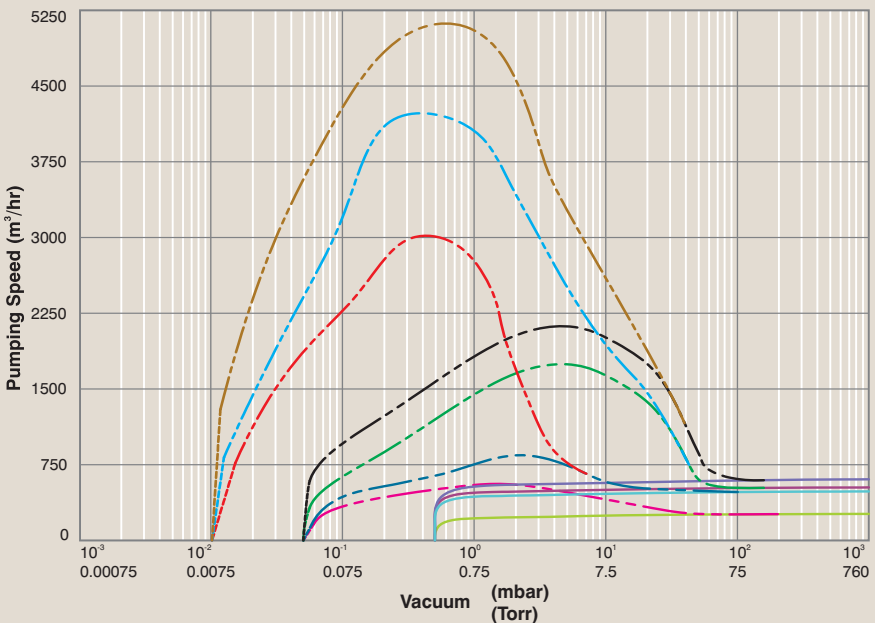

EVEREST ADVANTAGE

EVEREST HAS THE SKILL, EXPERTISE, KNOWLEDGE AND CAPABILITY THAT IT HAS ACQUIRED OVER THE YEARS TO CUSTOM DESIGN VACUUM SYSTEMS FOR SPECIFIC CUSTOMER REQUIREMENTS AND DELIVER GUARANTEED RESULTS

EVEREST PRODUCT RANGE

VACUUM

MECHANICAL VACUUM BOOSTERS
 DRY SCREW VACUUM PUMPS
 SUPERVAC
 ROTARY VANE VACUUM PUMP
 SUPERVANE
 VACUUM SYSTEMS (WET)
 ENGINEERED VACUUM SYSTEMS
 MECHANICAL VAPOUR RECOMPRESSOR (MVR|MVC)

PRESSURE

TWIN LOBE ROOTS BLOWERS
 TRI LOBE ROOTS BLOWERS
 CENTRIFUGAL BLOWERS
 TURBO BLOWERS
 BLOWER PACKAGES

INDUSTRIES SERVED

CHEMICAL & PHARMACEUTICAL

Degassers
 Vacuum Distillation
 Evaporators
 Crystallizers
 Vacuum Filters
 Vacuum Dryers

VACUUM FURNACE INDUSTRY

Heat Treatment
 Hardening
 Optical Coating
 Metallizing
 Degreasers in Furnace

ELECTRICAL INDUSTRY

Transformer Vacuum Impregnation
 Transformer Oil Purifier
 Vapour Phase Drying

INDUSTRIAL PROCESSING

Impregnating Windings
 Drying Textiles Mills
 Sterilizing re-circulation through Ethylene Dioxide
 Incandescent CFL and Tube Light Manufacturing
 TV Tubes Manufacture

FOOD PROCESSING INDUSTRY

Vacuum Packaging-Fresh & Cooked Meats
 Freeze Drying
 Deodorization of Vegetable Oil (FFA Distillation)
 Sugar Refining
 Vacuum Evaporative Cooling
 Vacuum Tray Drying
 Flash Drying

Our technology is so flexible, we can custom manufacture **Special Blowers, Vacuum Pumps & Systems** by alloying and cross linking diverse designs to suit individual requirements and import substitutes.



Corporate Office: B 44, Mayapuri Industrial Area, Phase 1, New Delhi 110 064, India
 T: +91 11 4545 7777 | E: sales@everestvacuum.com

    www.everestvacuum.com

We don't just offer **Blowers, Boosters and Systems** we offer **SOLUTIONS !!**